

Alpha System Boiler InTec S Range

These sophisticated system boilers represent the ultimate in boiler design, perfectly illustrating the ethos behind our new InTec range.

Alpha InTec12s, Alpha InTec18s, Alpha InTec28s System Boilers

Features

- Daily pump kick
- Frost thermostat
- Stainless steel heat exchanger
- Valves and tails factory fitted
- LCD display on control panel
- Detailed fault codes
- Grundfos pump and hydroblock assembly
- Easy-access NTCs on front of pipes
- Available for NG and LPG
-

As well as boasting the same level of advancement and innovation as our InTec combination boilers, they also have identical casing. This makes them one of the smallest system boilers available, something which aids positioning and installation.

With three outouts to choose from, InTec S models are ideal for any small to large home where a system boiler is the preferred option.

Optional accessory

The optional three-way diverter valve kit operates as a hot water priority valve, meaning if the heating is on and there is a hot water demand, the valve will divert the primary heat to the cylinder until the cylinder sensor is satisfied. Requires a quick recovery cylinder.

Model	Lift weight (kg)	DHW output (kW)	CH output (kW)	Flow rate l/min	NOx rating (mg/kWh)	Dimensions (mm)	GasSaver compatible	SolarSmart compatible	Standard guarantee	Guarantee with PP
InTec12S	35	-	13.2	-	-	720x440x300	■	●	5 yr	7 yr
InTec18S	36	-	20.0	-	-	720x440x300	■	●	5 yr	7 yr
InTec28S	39	-	30.7	-	-	720x440x300	■	●	5 yr	7 yr

User's Instructions

Alpha InTec 12S, 18S, 28S

**Range of Wall Mounted, Fan Assisted, Room Sealed,
Gas Fired, High Efficiency Condensing System Boilers**

For Technical help or for Service call ...
ALPHA HELPLINE Tel: 0844 871 8764
website: www.alpha-innovation.co.uk

Alpha
HEATING INNOVATION

Nepicar House, London Road,
Wrotham Heath, Sevenoaks,
Kent TN15 7RS

British Gas
Service Listed

CE 0051

WRAS
APPROVED
PRODUCT



For use with Natural Gas or Propane Gas (AS SUPPLIED)

Leave these instructions with the User

Please read these instructions carefully before operating your boiler.

1 INTRODUCTION

The Alpha InTec range of high efficiency condensing boilers incorporate the latest technology in boiler design. With improved burner efficiency and reduced electrical consumption together with high quality and reliability.

The boiler output will automatically adjust according to the requirements of the system.

The InTec range are designed to work with most central heating controls however we recommend the Alpha two channel versions of built in clock or Comfort RF external thermostat programmer.

Alternatively with the use of the Alpha system diverter kit the enhanced Alpha Climatic boiler energy manager can be used to increase comfort and efficiency. When using the Climatic control unit the efficiency can be further enhanced with the use of the outside sensor to enable the boiler's built in weather compensation feature.

The boilers will provide both central heating and hot water when required according to the times and temperatures set by the controls fitted. Hot water cylinder heating will take priority over heating. Simultaneous heating and hot water can be achieved when using a mid position Y-plan valve or S-plan system.

2 OPERATING THE BOILER

The boiler controls are located on the control panel located behind a drop down flap.

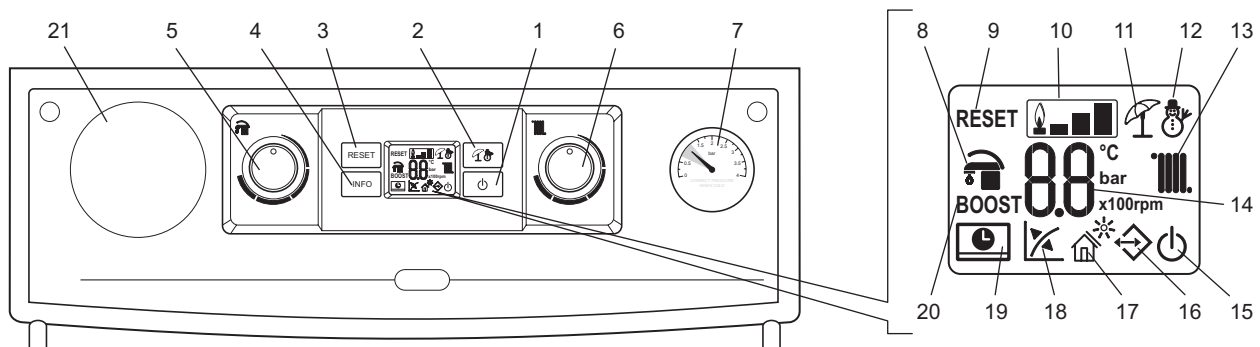

- | | | |
|-----------------------------------------------------|-----------------------------------------------------------|------------------------------------------------------------------|
| 1 On-Off/Standby button | 9 Boiler locked does not require reset via "RESET" button | 16 Presence of external connected devices |
| 2 Summer/Winter button | 10 Flame present symbol and relative power scale | 17 Solar function active |
| 3 Reset button | 11* Operating in summer mode | 18 Functioning with external temperature probe active (optional) |
| 4 Information button | 12 Operating in winter mode | 19 Boiler connected to remote control (optional) |
| 5* Domestic hot water temperature selector switch | 13 Central heating mode active | 20 Not used on this model |
| 6 Central heating water temperature selector switch | 14 Temperature indicator, boiler info and error codes | 21 Optional boiler controls (if fitted) |
| 7 Heating system pressure gauge | 15 Boiler in Stand-by mode | |
| 8* DHW mode active | | |

*The summer hot water mode and hot water temperature selector switch will only function when using the Alpha System Diverter kit in conjunction with a hot water cylinder. When using a standard Y or S plan system the boiler **must be** left in winter mode and only the Heating thermostat used.

Fig. 1

Make sure the heating system is filled and the needle on the pressure gauge (item 7 in Fig. 1) is in the green band. If incorrect refer to Section 4.

Switch the boiler on at the mains supply socket switch. The boiler will automatically go through a system purging operation for 8 minutes; this is indicated by a count down on the display starting from 96. During this operation the pump will turn on and off to help remove any air that may be trapped in the heating system. If the boiler has already been commissioned by the installer then this operation can be terminated by pressing the reset button (item 3 in Fig. 1).

Note: It is important to allow this purging operation to function when the boiler has been initially installed to remove all the air from the system.

After this purging operation the boiler will be in 'Standby' or 'On' mode.

By pressing the On-Off button (item 1 in Fig. 1) the Standby or On mode can be selected, or press and hold the On-Off button for eight seconds to turn the boiler off.

Standby - In this mode the boiler will not provide hot water or central heating, but frost protection and pump circulation features are still active.

Off - In this mode there is electrical power to the boiler but the boiler will not function in any condition.

On - In this mode the boiler can be switched between 'Summer' or 'Winter' settings by pressing the Summer/Winter button (item 2 in Fig. 1).

Press the Summer/Winter button (item 2 in Fig. 1) to select either heating and hot water or hot water only.
If an InTec S boiler is used with a conventional Y-plan, the boiler must be set to winter mode to provide heat to the hot water cylinder.

3 HEATING AND HOT WATER TEMPERATURE

Summer setting - This function can only be used if the boiler is fitted with an Alpha System kit allowing control of the hot water cylinder using the boiler controls. This has the added advantage of allowing you to independently control the temperature of the heating hot water and the cylinder hot water. In this mode the boiler will only supply hot water to the cylinder when the temperature of the cylinder water is below that set by the hot water selector switch (item 5 in Fig. 1). When heating the hot water cylinder the central heating will not function even if requested by any controls. The desired hot water cylinder temperature can be set using the hot water selector switch.

Winter setting - In this mode the boiler will operate to requests for both heating and hot water. For a system fitted with a standard Y or S plan the boiler should always be left in the winter mode. The boiler will always prioritise hot water when requested by external controls. The heating will activate depending on the request from any external controls fitted. The LCD display will then display the actual temperature of the water leaving the boiler when operating to provide heating or hot water.

Note: When using a standard Y or S plan system the central heating selector switch (item 6 in Fig. 1) must be set above the cylinder thermostat value.

External weather compensation probe (only for use with the Alpha system diverter kit) - The temperature of the central heating water can be adjusted by turning the central heating selector switch (item 6 in Fig. 1). When the heating is on the temperature of the water leaving the boiler to the radiators will be displayed.

If an external weather compensation probe is fitted, indicated by the  symbol (item 18 in Fig. 1) in the display, it will automatically vary the temperature of the water in the radiators and on mild day the radiators will not feel as hot as on a cold day, this is normal and not a fault with the boiler or heating circuit. The room temperature will still be maintained as set by the room thermostat.

When an external weather probe is fitted, the central heating selector switch (item 6 in Fig. 1) will no longer adjust the flow temperature in °C, instead the display will show a scale of 1 to 9. Each number corresponds to a line on the graph in Fig 2 i.e. line 6 will give a flow temperature of 60°C when the external temperature is 10°C.

Note: This is the temperature of the water supplied to the radiators and not the desired room temperature. The time and temperature will still be maintained according to the setting of the room thermostat.

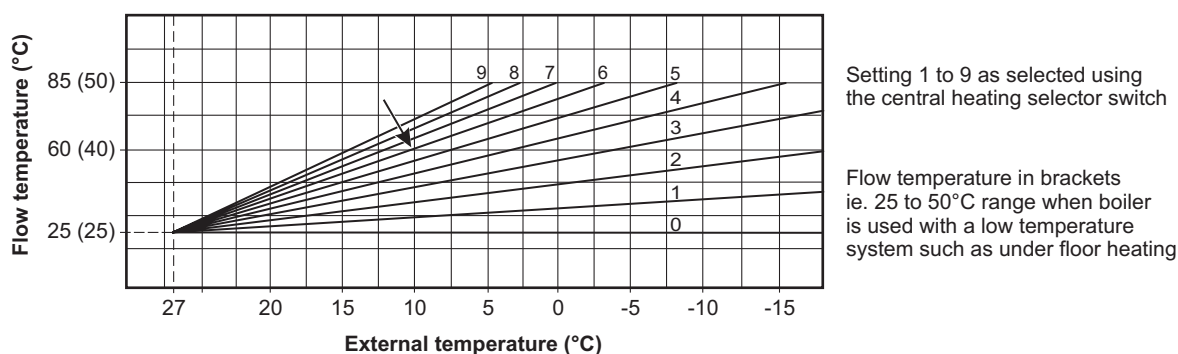

Fig. 2 - External weather compensation probe fitted

4 FILL AND PRESSURISE THE SYSTEM

InTec S models should have a filling loop fitted by the installer located in the pipework close to the boiler.

Do not attempt to fill or pressurise the system while the system is hot - wait for it to cool.

The filling loop will have two tap connections at either end of the filling loop. These taps should normally be in the closed position 90° to the tap housing.

To fill or pressurise the system open one tap fully by turning it 90° anticlockwise in line with the tap housing. The second tap should be opened a quarter of a turn and the water will start to refill the system (water should be heard filling the system). You should see the pressure gauge (item 7 in Fig. 1) rise back up into the green area on the pressure gauge between 1 bar and 1.5 bar pressure.

Once the pressure gauge is in the green area turn the taps back to the off position and the water will stop filling the system. If you happen to fill the system too much and the pressure gauge is over the green area, just bleed water from a radiator until the pressure on the gauge goes down into the green area.

5 INFORMATION MENU

By pressing the info button (item 4 in Fig. 1) the information menu is accessed this will then show the information according to the table below.

Info Menu (d - prefix)	Information	Units Shown
d1	Flame signal	µA x 10 (approx)
d2	Central heating water temperature leaving the boiler	°C
d3	Domestic hot water cylinder temperature (only if Alpha System diverter valve kit fitted)	°C
d4	Central heating set point temperature	°C
d5	Domestic hot water set point temperature (only if Alpha System diverter valve kit fitted)	°C
d6	External weather compensation probe temperature (value flashes if negative)	°C
d7	Not used	
d8	Not used	
d9	Fault history - by rotating the CH knob (item 6 in Fig. 1) in this menu the last five faults will be displayed	Error code

6 FROST PROTECTION

The boiler has a built in frost protection function to protect the boiler (only) from freezing. If water within the boiler falls below 4°C the boiler will fire in heating mode and raise the temperature of the heating water (in the boiler only) to 30°C.

For this function to be active the gas and electricity supplies to the boiler must be turned on and the boiler be in either 'Standby' or 'On' mode.

Further protection for the mains water supply and heating circuit must be provided separately.

If Alpha external controls are fitted, a frost protection setting is incorporated into the room thermostat activating the central heating when the temperature falls below 5°C.

7 CONDENSATE DRAINAGE

High efficiency (condensing) boilers remove more useful heat from the combustion gases, resulting in additional water vapour which is collected within the boiler (as condensate) and run to a suitable drainage point via the condensate drainage pipe.

If the condensate drain pipe runs outside it should be fitted with increased diameter pipe and be suitably lagged to reduce the risk from freezing.

In situations where there are likely to be extremes of temperature or wind-chill the use of a proprietary trace-heating system for external condensate drainage pipework, incorporating an external frost thermostat, should be considered.

8 OPERATIONAL FAULTS

The InTec range of boilers are fitted with a fault code display feature.

If a fault occurs a fault code will be displayed in the LCD display screen (item 14 in Fig. 1), indicated with an alternating flashing E followed by the fault code. A list of fault codes are given in the table below.

In the event of a fault occurring firstly check that the gas and electricity supplies are on and that any external controls fitted are set and working correctly.

Press the reset button (item 3 in Fig. 1) on the control panel to restart the boiler if the fault occurs again, make a note of the fault code and contact your installer or Alpha technical Helpline for further advice.

Error code	Fault	Fault description	Possible causes
01	Ignition failure	Flame not detected during ignition sequence	Gas supply Check pressure tubes Ignition electrode gap Flame sensor electrode gap Ignition generator or lead Flame sensor electrode lead Gas valve setting Gas valve PCB
02	Overheat boiler lock out	Overheat thermostat or thermal fuse has operated	Pump or flow problem Blocked heat exchanger Air in heat exchanger Overheat thermostat Thermal fuse (if open circuit then replace primary heat exchanger)
03	High flue thermostat temperature	Flue thermostat intervention (flue temperature over 113°C)	Blocked or restricted primary flow Heat exchanger air flow blocked Flue restriction Flue sensor fault
04	Gas valve electrical connection fault	Gas valve wiring circuit fault detected	Gas valve lead connection fault Faulty gas valve Faulty PCB
05	Heating flow sensor fault	Incorrect flow sensor resistance value	Flow sensor wire connections Flow sensor faulty
06	DHW sensor fault (InTec C, X, GS only)	DHW sensor resistance value is incorrect	DHW sensor wiring connection DHW sensor faulty
08	Maximum number of resets	Maximum number of resets reached (5)	Refer to fault history codes (INFO menu d9)
10	Primary system pressure low	Primary pressure switch has operated	Check expansion vessel pressure (1 bar) Leak in system Expansion relief valve operated Primary pressure switch
12	Cylinder sensor fault (InTec S and FlowSmart only)	Incorrect cylinder sensor resistance	Cylinder sensor wiring connections Cylinder sensor faulty
15	Internal wiring error	Incorrect wiring configuration detected	Check internal wiring connections to PCB Combination boiler DHW sensor X4 System boiler link X14 Refer to wiring diagram

Error code	Fault	Fault description	Possible causes
16	Fan fault	Fan wiring fault or fan faulty	Check fan wiring connections Fan fault PCB fault
20	Flame sensing fault	False flame detection Flame detected but gas valve is not open	Check flame sensing electrode and lead PCB fault
24	Control panel button fault	Control panel button stuck in the on position	Check for jammed control panel buttons Check for jammed PCB buttons
25	Overheat lock out	Rapid temperature rise of flue sensor	Air in heat exchanger Blocked or restricted primary flow Heat exchanger air flow blocked Flue restriction Flue sensor fault Pump fault Boiler or heating circuit valve closed
27	Insufficient primary flow	Rapid temperature rise of primary sensor	Blocked or restricted primary flow Air in heat exchanger Boiler or heating circuit valve closed Pump fault Primary flow sensor fault
29	Flue sensor fault	Flue sensor resistance out of range	Check sensor wiring connection Flue sensor faulty
31	Loss of communication with external control (Alpha Climatic)	Loss of connection between the boiler and Alpha Climatic control unit	Remote control or receiver connection wiring Remote control or receiver
37	Low supply voltage	Insufficient supply voltage to operate boiler	Check mains power supply
38	Loss of flame rectification	Flame detected but signal is lost. Ignition reattempts after fan purge	Check flame sensing electrode and lead Check for flue gas recirculation Check/adjust the gas valve settings Check/adjust the fan speed settings
43	Loss of flame rectification	Repeated loss of flame signal during operation (shown as E38 in the fault code history in the INFO menu)	Check gas supply/working pressure Check flame sensing electrode and lead Check for flue gas recirculation Check/adjust the gas valve settings Check/adjust the fan speed settings
44	Safety lock out	The boiler has attempted to fire repeatedly for the maximum time limit	Check external control (room thermostat) requests Rapid on/off hot tap requests
46	External sensor intervention	No continuity of external sensor circuit	Check external sensor and cable are not damaged or wet Check continuity of external sensor and circuit Check connection at X19 on PCB and sensor connecting block
47	Reduced burner output	Flue thermostat has sensed high flue gas temperature (110°C) and reduced the burner output to prevent damage. If the temperature continues to rise the boiler will lock out and E03 will be displayed	Air in heat exchanger Restricted primary flow Heat exchanger air flow blocked Flue restriction Flue sensor fault Pump fault

9 IMPORTANT NOTES

1. BOILER LOCATION

Always ensure the following clearances are available around the casing of the boiler:-

Top: (horizontal flue) 235 mm, **Top:** (vertical flue) 150 mm, **Bottom:** 150 mm, **Bottom:** (with Jig) 250 mm,
Each side: 5 mm, **Front:** 450 mm

Do not store any other articles in a cupboard containing the boiler and never place any clothing or combustible material on or near the boiler or flue pipe.

2. FLUE TERMINAL

The terminal on the outside wall must not be allowed to be obstructed. If it is damaged, in any way, turn the boiler off and contact your Service Engineer.

Note: The Alpha InTec boilers are high efficiency condensing boilers and when operating vapour will be emitted from the terminal. This is safe and quite normal.

3. MAINS FAILURE

In the event of an electrical supply failure the boiler will not operate. When the supply is restored, the boiler will return to normal operation. Remember to reset any controls, if fitted, when the supply is restored. If the mains water supply fails, there will be no hot water from the taps. The boiler will continue to provide central heating.

4. ADDITIONAL BATHROOM FITTINGS

Any equipment such as mixing valves, showers, bidets etc. must be designed to operate at mains water pressure. Contact your plumbing merchant or installer for advice when considering purchasing such items.

5. CLEANING

Use only a damp cloth and mild detergent to clean the boiler outer casing. Do not use abrasive cleaners.

6. SERVICING

To maintain efficient and safe operation of your boiler, routine annual servicing is essential. For advice on servicing contact:- The Alpha Helpline: 0844 871 8764.

7. GAS LEAK

If a fault or gas leak is suspected, turn off the gas supply. Do not touch any electrical switches, do not smoke and extinguish all naked flames. Contact your local Gas Region immediately on 0800 111 999.

8. ELECTRICAL SUPPLY

The boiler requires a 230/240 V ~ 50 Hz supply, fused at 3 A if a 13 A 3-pin plug is used or a 5 A fuse if any other type of plug is used.

To connect a plug:-

The colour of the wires in the mains lead of the boiler may not correspond with the coloured markings identifying the terminals in your plug. In this case proceed as follows:-

The wire coloured green and yellow must be connected to the terminal in the plug that is marked with the letter **E**, or by the earth symbol ⏏ , or coloured green or green and yellow.

The blue wire must be connected to the terminal which is marked with either the letter **N** or coloured black.

The brown wire must be connected to the terminal which is marked with the letter **L** or coloured red.

THE APPLIANCE MUST BE EARTHED.

10 GAS SAFETY REGULATIONS

Current Gas Safety (Installation and Use) Regulations:-

It is the law that all gas appliances are installed and serviced by a competent person, i.e. Gas Safe registered personnel. Failure to install or service appliances correctly could lead to prosecution. It is in your interest and that of safety to ensure compliance with the law. The manufacturer's instructions must not be taken in any way as over-riding statutory obligations.

The Benchmark Checklist must be fully completed by the installer on installation of the boiler. The Benchmark Checklist is shown in back of the Installation and Servicing instructions. All Gas Safe registered installers carry a Gas Safe ID card and have a registration number. Both should be recorded in the Checklist. You can check your installer is Gas Safe registered by calling Gas Safe on 0800 408 5500.

11 OPTIONAL BOILER CONTROLS (if fitted)

There is a range of controls available from Alpha to operate your boiler. In addition to the items listed below the Alpha InTec boilers are compatible with most controls available on the market. However to get the most comfort and efficiency from your boiler we recommend the Alpha Climatic controls with enhanced remote boiler functions and efficiency control.

Please refer to the instructions provided with the controls for further information on their setting and use.

Available Alpha controls:

7 day digital heating clock- two channel (boiler mounted)	Part No.6.1000220
Alpha Comfort 7 day wireless programmable room thermostat - two channel (boiler mounted receiver) ..	Part No.3.022142
*Alpha Climatic wired programmable boiler energy manager (boiler mounted)	Part No. 3.022144
*Alpha Climatic wireless programmable boiler energy manager (boiler mounted receiver)	Part No. 3.022143
*External weather compensation probe.....	Part No. 3.022383
Alpha System diverter valve kit	Part No. 3.022382
Optional boiler controlled condensate trace heating kit.....	Part No. 6.5500000

* These controls can only be used in conjunction with the Alpha System diverter valve kit.

Alpha

HEATING INNOVATION

Alpha Therm Limited.
Nepicar House, London Road, Wrotham Heath,
Sevenoaks, Kent TN15 7RS
Tel: 0844 871 8764

email: info@alpha-innovation.co.uk
website: www.alpha-innovation.co.uk

*These instructions have been carefully prepared but we reserve the right to alter the specification at any time in the interest of product improvement.
© Alpha Therm Limited 2011.*

Part No. 1.030786 Rev 15.035285/000